

Wind Screen

Assembly Instructions

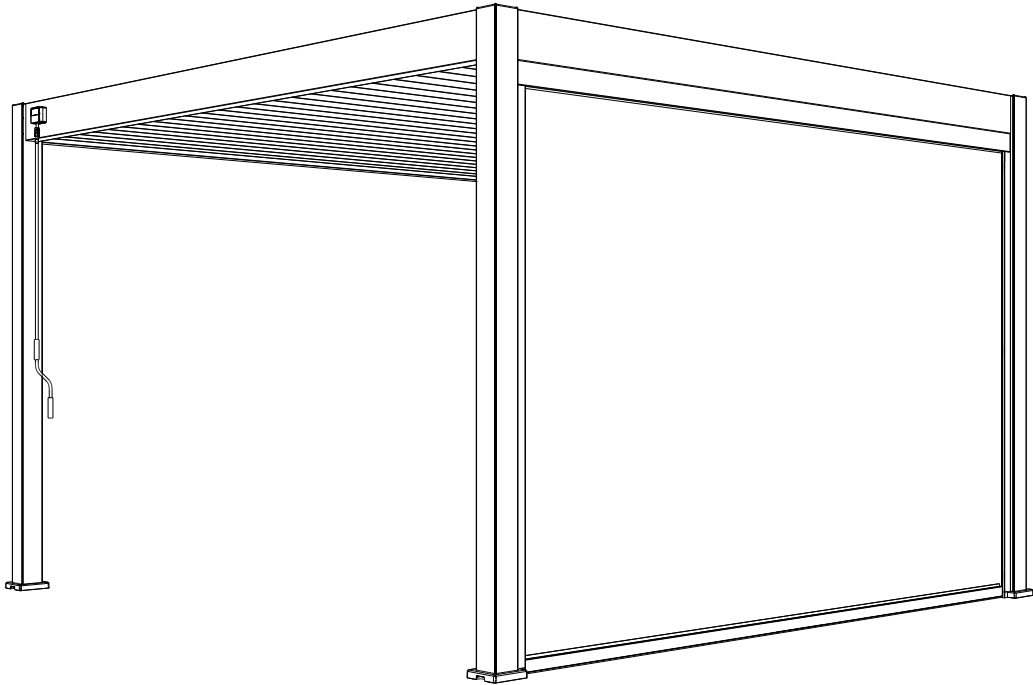

Register your pergola at www.paragon-outdoor.com for an extra **1 year** of coverage!



Paragon Group USA

Customer Service Contact Information: 1-877-782-4482

support@paragon-outdoor.com

©     @paragonoutdoorcompany

Wind Screen

Please read the following instructions completely before you begin assembly. Any errors made during installation are not covered by the product's warranty. If you have any questions during the installation process, please call us at 1-877-782-4482.

NECESSARY TOOLS AND SAFETY GEAR (NOT SUPPLIED)

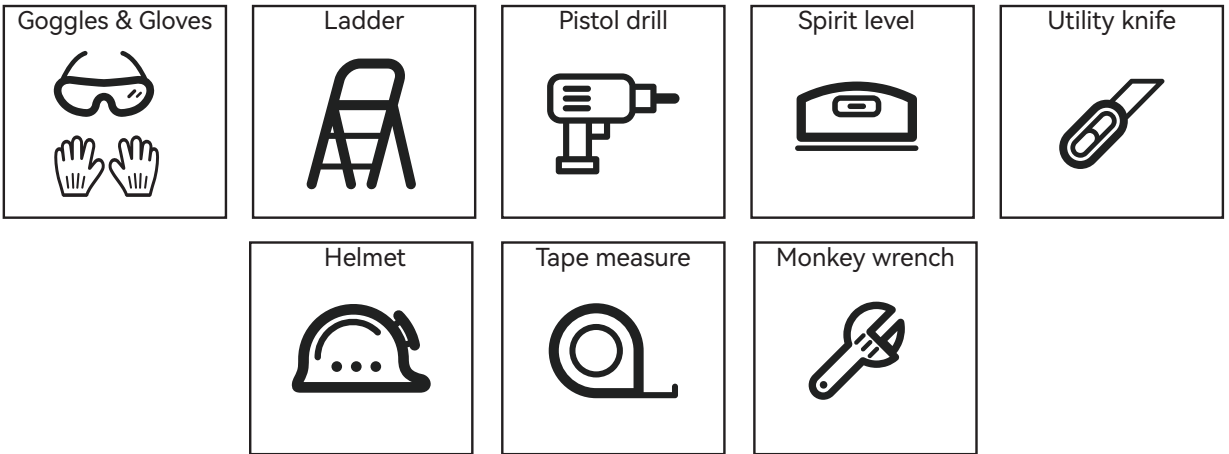

Paragon Outdoor's 5 Year Limited Warranty

Items Included in Warranty: PRGRT-1012GY, PRGRT-1214GY, PRGRT-1220GY

Limited Warranty

Paragon Outdoor warrants to the original purchaser that all components and hardware in its products, under normal use and service conditions, will be free from defects in manufacturing and materials for a period of 5 years* from the date of original retail purchase subject to the definitions, terms and conditions contained in this warranty. This warranty period covers all parts including aluminum, steel, hardware and accessories.

Paragon Outdoor will replace any defective part within the warranty period, at its discretion, if it is found to be defective of workmanship or materials. Paragon Outdoor may request photographs, videos, or physical return of the defective part for verification purposes.

Warranty Conditions

1. This warranty shall be valid only if the product is installed, cleaned, handled and maintained in accordance with Paragon Outdoor's written recommendations listed below.
2. Without derogating from the above, damage caused by use of force, incorrect handling, inappropriate use, neglectful use or assembly or maintenance, accidents, impact from foreign objects, vandalism, pollutants, alteration, painting, connecting, gluing, sealing not in accordance with the user's manual, or damage resulting from cleaning with incompatible detergents and minor deviations of the product are not covered by this warranty.
3. This warranty does not apply to damage resulting from "force majeure", which includes but is not limited to, hail, storm, tornado, hurricane, blizzard, flood, or fire effects, beyond stated claims.
4. This warranty is void if structural parts and components used are not compatible with Paragon Outdoor's written recommendations.
5. This warranty applies to the original owner and registrant and is non-transferable.

SKU/Series/Item	Warranty Duration	Extended Warranty
PRGRT-1012GY, PRGRT-1214GY, PRGRT-1220GY	4 years	+ 1 year

*Extended warranty is applied when product is registered on www.paragon-outdoor.com within 1 month of purchase.

Operation: Hard-Top Gazebos and Pergolas

1. These are four-season products, meaning that they may be left up year-round. However, any accumulation of snow must always be removed from the roof of the unit.
2. The unit must be anchored using the appropriate hardware based on the flooring in which it is being anchored to.
3. Check all hardware for tightness before and during usage of the unit. Tighten screws at least twice a year.
4. The maximum weight allowance for an accessory attached to the center beam is 40 lbs.
5. If your product allows it, remove any mosquito netting and curtains during the winter months.

Planning Assembly

1. It is the consumer's responsibility to comply with building rules, regulations, zoning restrictions or any other regional restrictions and obtain the required permits before purchasing the product and installing it.
2. Make sure that every part is in the box before beginning installation.
3. Some parts may have sharp edges; it is recommended to wear gloves, protective eyewear and closed shoes.
4. You must schedule enough time to complete assembly as you cannot leave the product unattended if it is not fully assembled, even if bolted to the ground.
5. A minimum of 3 people are required for a safe assembly of the product. This will vary depending on certain steps of installation.
6. Follow each instruction manual carefully to ensure the strength of the product.
7. To avoid damage to the product and its part, use the proper tools. Do not use the product as a support. The use of a ladder may be necessary at certain stages of assembly.
8. Keep the instruction manual and the parts list in case of future needs or references.
9. Do not assemble the product on days of wind or rain.

Maintenance

For all products:

1. In case of a defective part or if a problem occurs while using this product, please contact Paragon Outdoor Customer Service at (877) 782-4482.
2. To order replacement parts, identify the model number and the part number found in your assembly manual.
3. Optional accessories may be available for your product such as mosquito nets, curtains, canopy replacements or more. Please contact your retailer for more information.

Safety Information

IT IS VERY IMPORTANT TO READ AND FOLLOW ALL SAFETY PRECAUTIONS BEFORE ASSEMBLY AND DURING USE OF THE PRODUCT.

1. Keep children and pets away from assembly area.
2. When assembling and using the product, basic safety precautions must always be followed to reduce risks of personal injuries and damages to the product and its surroundings.
3. Ensure that all parts are in the boxes before starting the assembly. It is recommended to wear protective gloves since some of the parts have sharp edges.
4. Begin the assembly and install the product more than 10 ft. away from any obstructions including, but not limited to, a fence, overhanging branches, a laundry line or electrical wire and as much as possible in a place protected from the wind.
5. Always install the product on a level platform and be anchored according to the surface recommendations in the assembly instructions.
6. Check all hardware for tightness before and during the use of the product. Tighten screws at least twice a year.
7. Do not install the product in a space where there is a possibility of high winds.

Care and Cleaning

For all products:

1. For cleaning: use a mild soap or soft detergent and wash with warm water using a sponge or fabric cloth. Rinse with clean water.
2. Snow must always be removed from the roof of the unit.

Customer Service Contact

If you are experiencing any issues with the assembly of your new structure, please do not return – our expert customer service team will help you with all questions for a smooth assembly process.

Email: support@paragon-outdoor.com









Need Assistance? Call: +1 (877) 782-4482

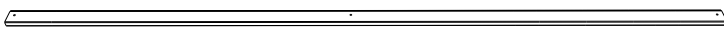

Hours of Operation

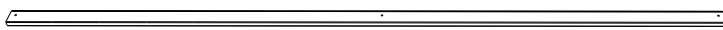
Speak with an Expert Customer Service Agent: Monday – Friday: 8:00 am – 5:00 pm CST

We are available 24 hours a day, 7 days a week. Please allow up to 24 hours for a response.

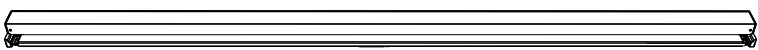
CARTON LIST

Reference	Parts	Quantity
A		1
	A-1 	1
	A-2 	1
	A-3 	1
	A-4 	3
B		1
	B-1 	1
	B-2 	1
	B-3 	1
	B-4 	3
C-1		1

Reference	Parts	Quantity
K1	 5x19	8
K2	 3mm	1

Reference	Parts	Quantity
K3	 8mm	1

Before installation, please make sure the dimension should be correct as the diagram shows below, namely, $A1=A2=A3$ and $AX=BX$.

Please do not install the wind screen if the dimension is incorrect. Please adjust the finished size before installing.

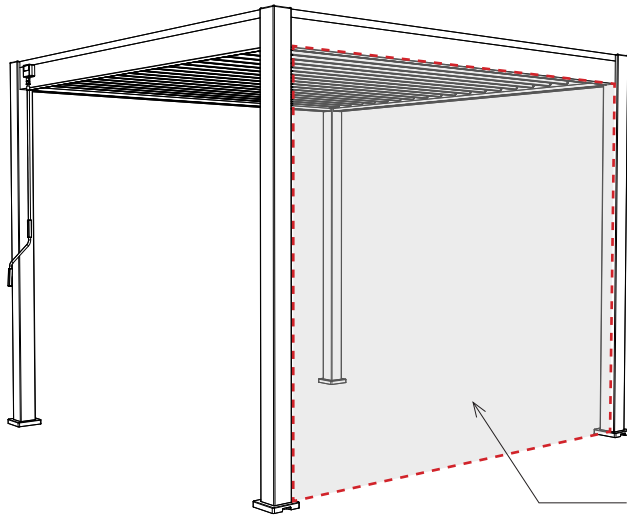

Please choose which face to install the wind screen.

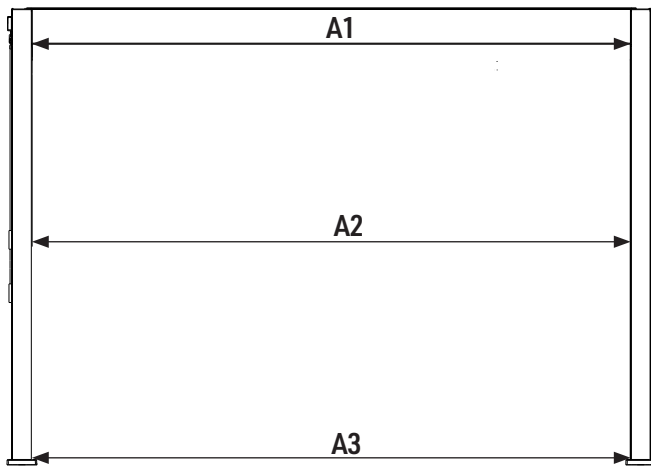

$$A1=A2=A3$$

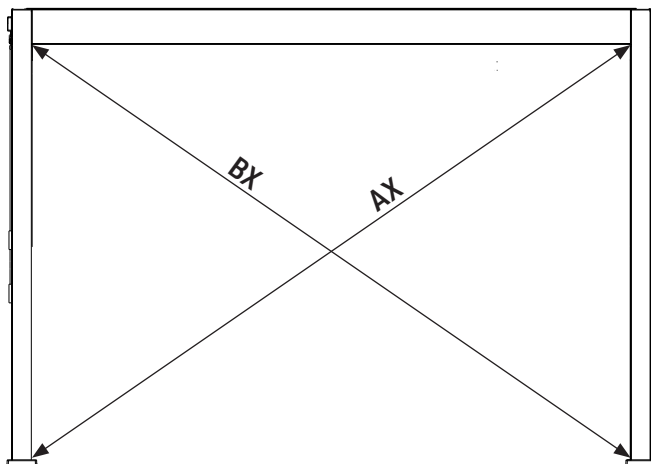

$$AX=BX$$

STEP 1

Disassemble the post **A** and **B** as shown above.

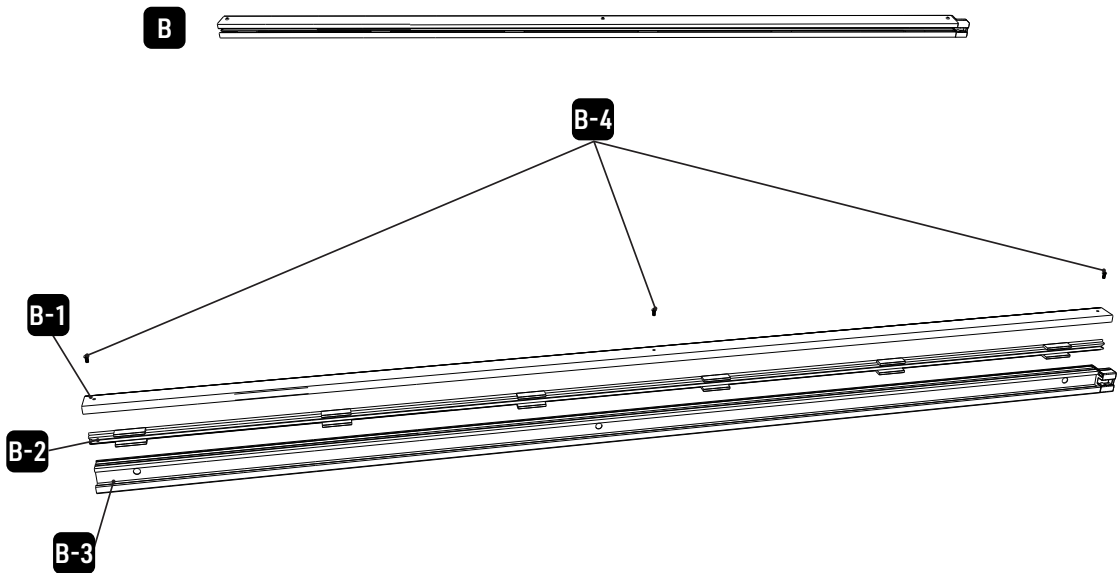
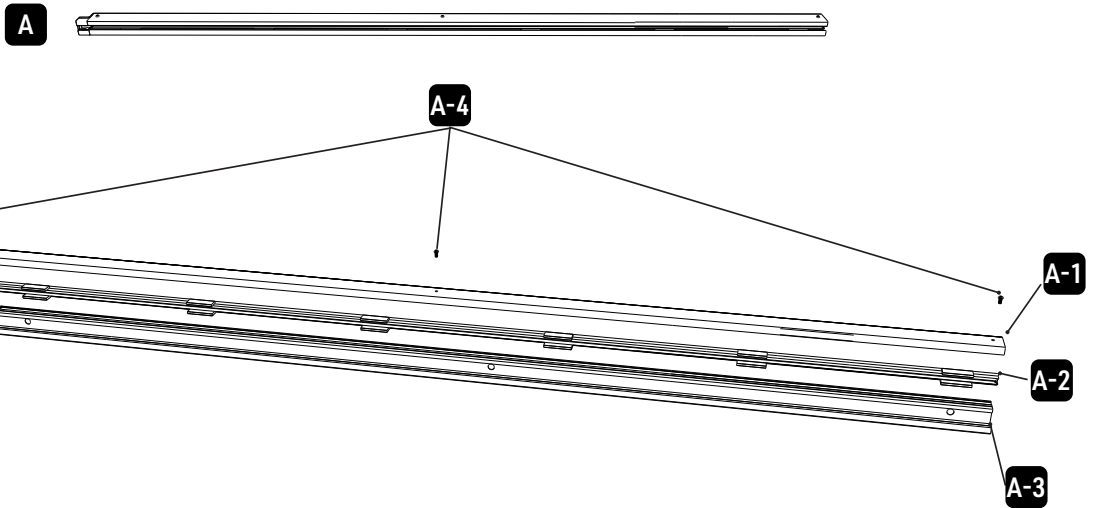

STEP 2

Insert A-3/B-3 into the side panel of wind screen box (C1).

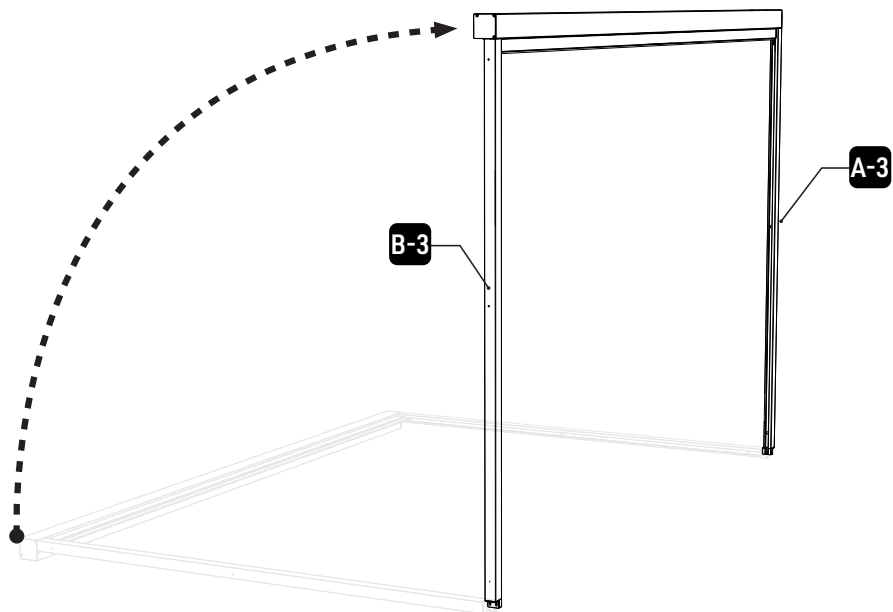
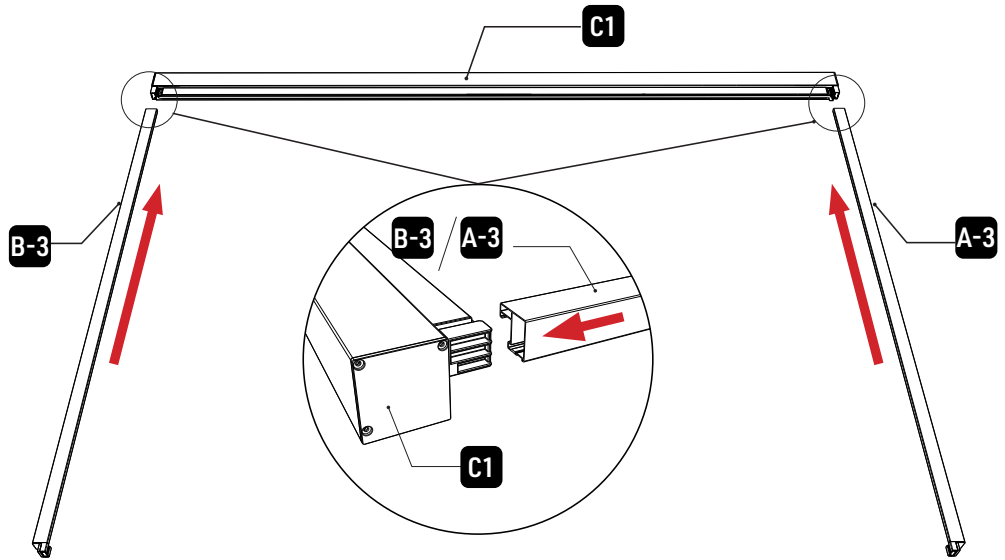

STEP 3

Put the frame up and make sure the outer face of wind screen box align with outer face of beam.

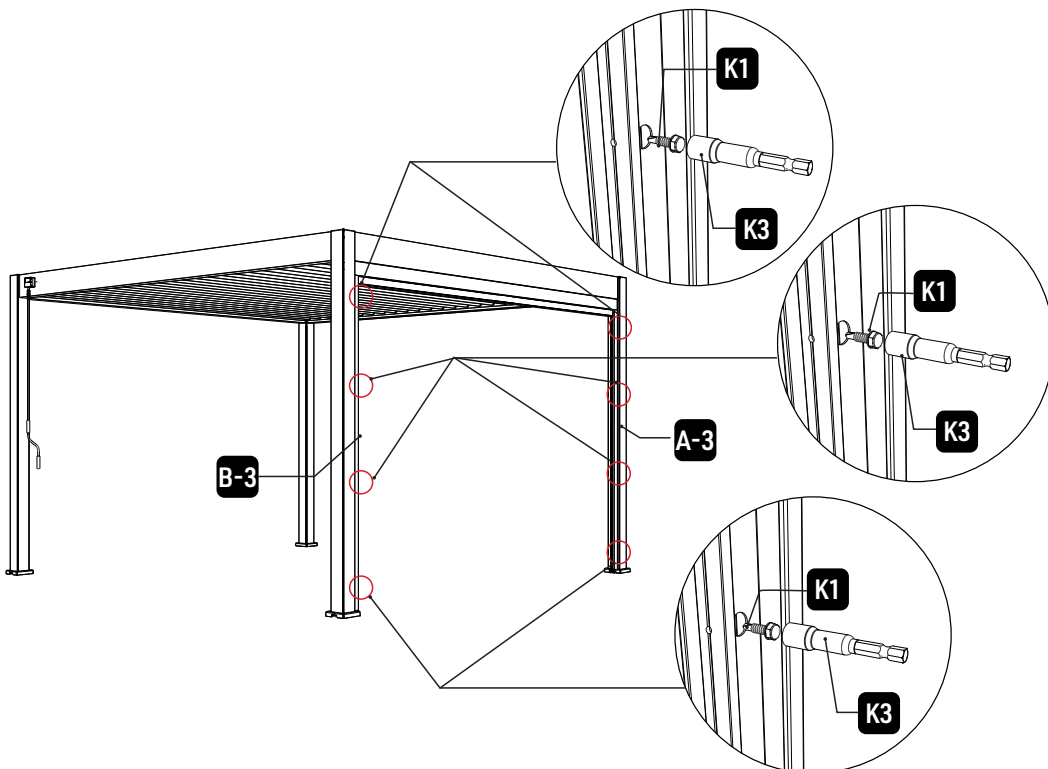
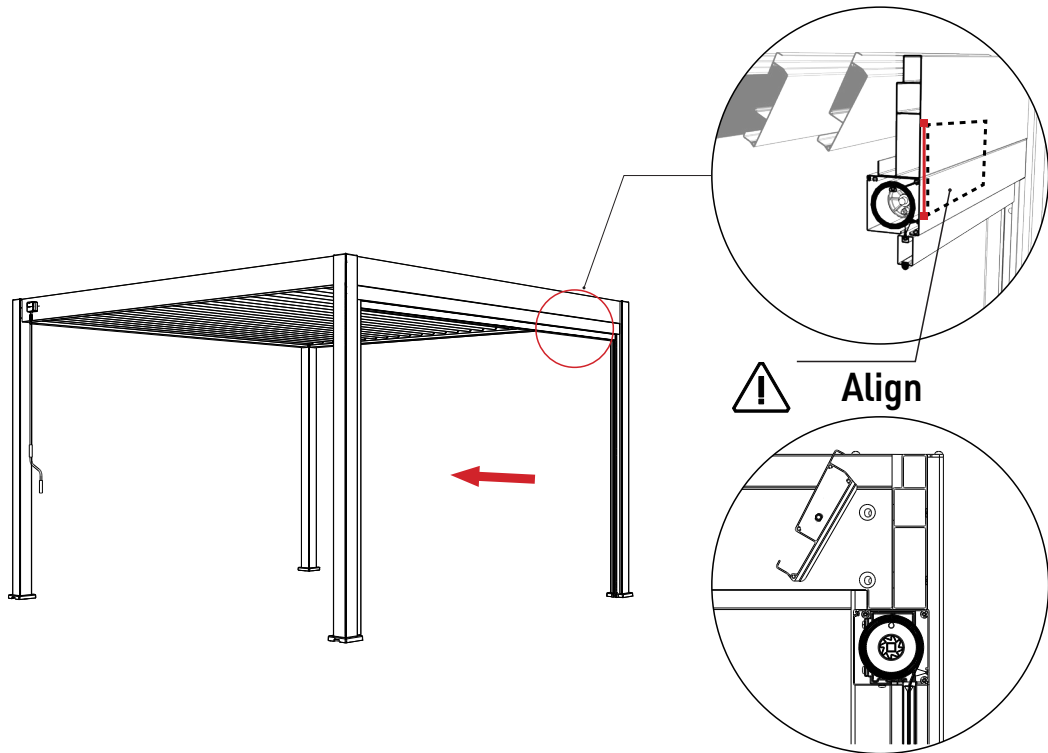

STEP 4

- Insert **A-2** diagonally into the channel of **A-3**.
- Make sure the notch of **A-2** meet to side zipper along the screen.
- Place **A-2** vertically into the channel of **A-3**.
- Repeat the same process in the other side.

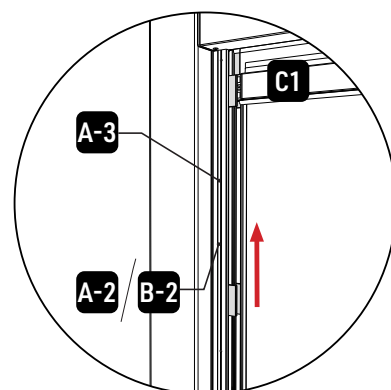
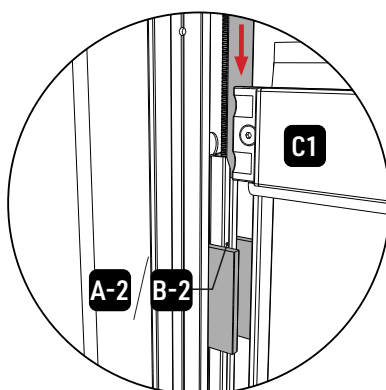
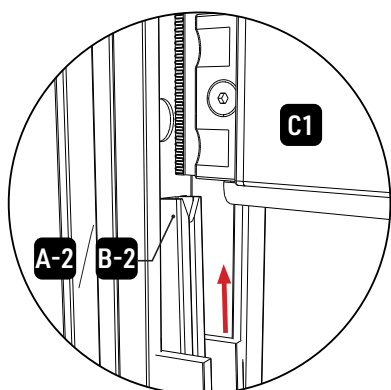
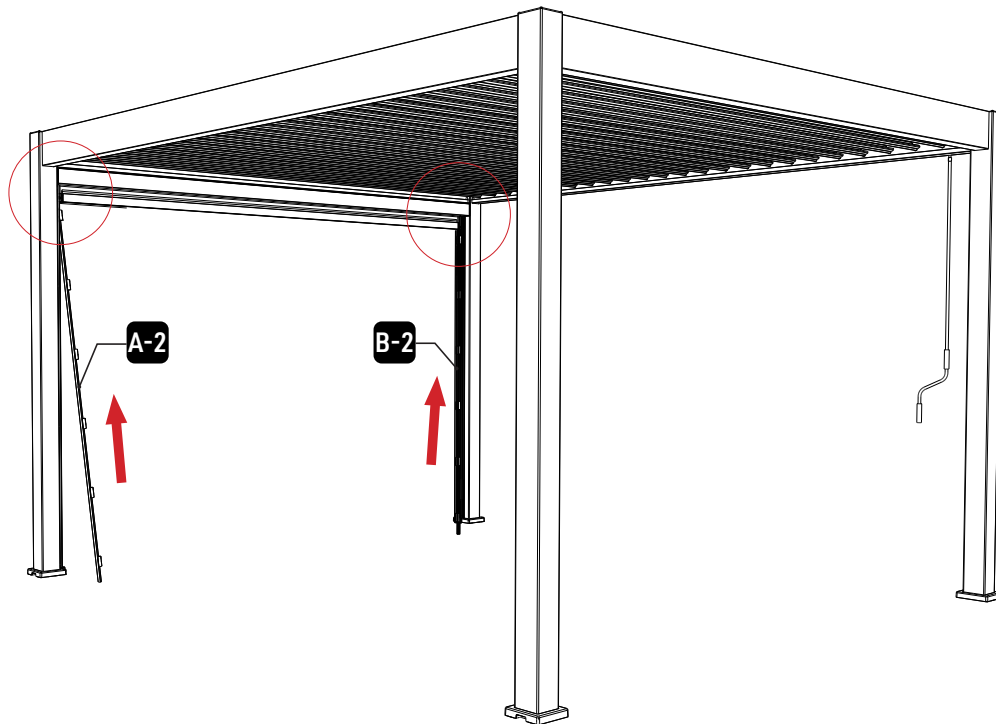

STEP 5

- Insert post cover (A-1/B-1) to the post
- Settle sponge block into right position (see below)
- Fix screw slightly (not too tight)
- Test the screen up and down
- Fix all screws when you confirm screen is running well.

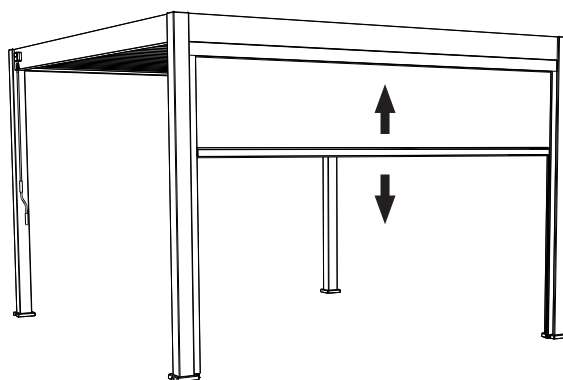
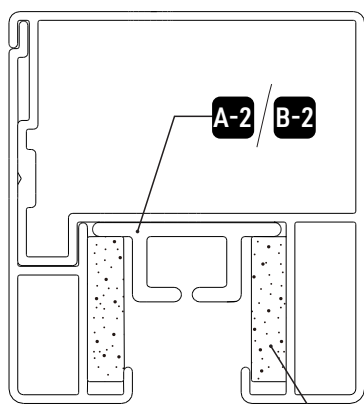
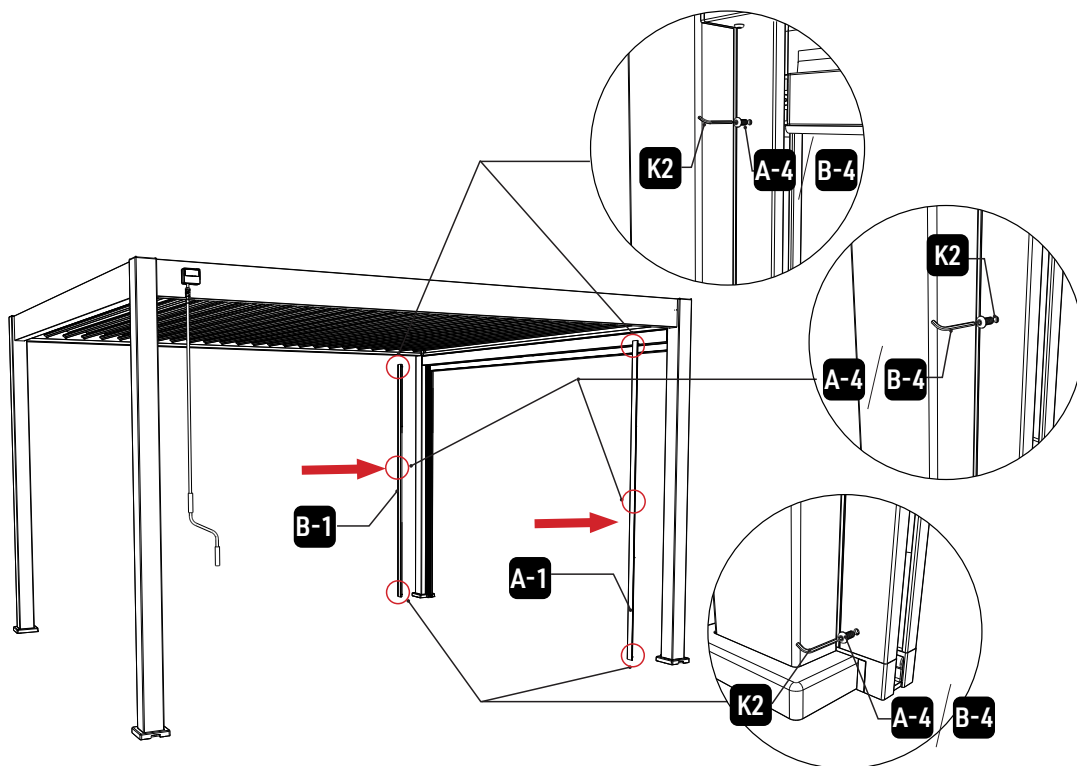

Please make sure the foam strip on the sides of A-2/B-2 can be inserted into the U groove of the wind screen's frame.



Paragon Group USA

Customer Service Contact Information: 1-877-782-4482
support@paragon-outdoor.com

 @paragonoutdoorcompany